

High Performance Computing (HPC) Using zcluster at GACRC

On-class STAT8060

Georgia Advanced Computing Resource Center

University of Georgia

Zhuofei Hou, HPC Trainer

zhuofei@uga.edu

Outline

- What is GACRC?
- What is HPC Concept?
- What is zcluster?
- How to work with zcluster?

What is GACRC?

Who Are We?

- Georgia **A**dvanced **C**omputing **R**esource **C**enter
- Collaboration between the Office of Vice President for Research (**OVPR**) and the Office of the Vice President for Information Technology (**OVPIT**)
- Guided by a faculty advisory committee (GACRC-AC)

Why Are We Here?

- To provide computing hardware and network infrastructure in support of high-performance computing (**HPC**) at UGA

Where Are We?

- <http://gacrc.uga.edu> (Web) <http://wiki.gacrc.uga.edu> (Wiki)
- https://wiki.gacrc.uga.edu/wiki/Getting_Help (Support)
- <https://blog.gacrc.uga.edu> (Blog) <http://forums.gacrc.uga.edu> (Forums)

What is HPC Concept

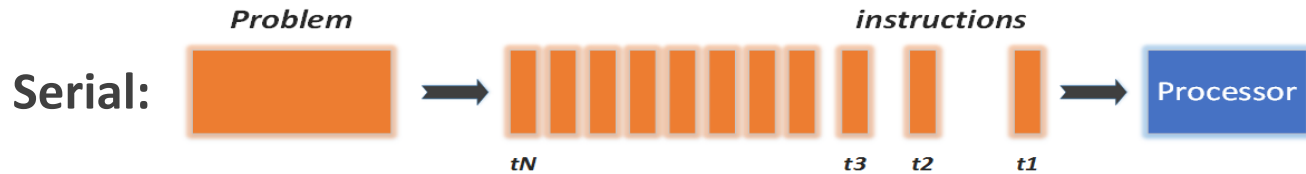

- ✓ Problem broken into **discrete** instructions
- ✓ Instructions executed **sequentially**
- ✓ Only **1** instruction executed at any moment on a **single processor**

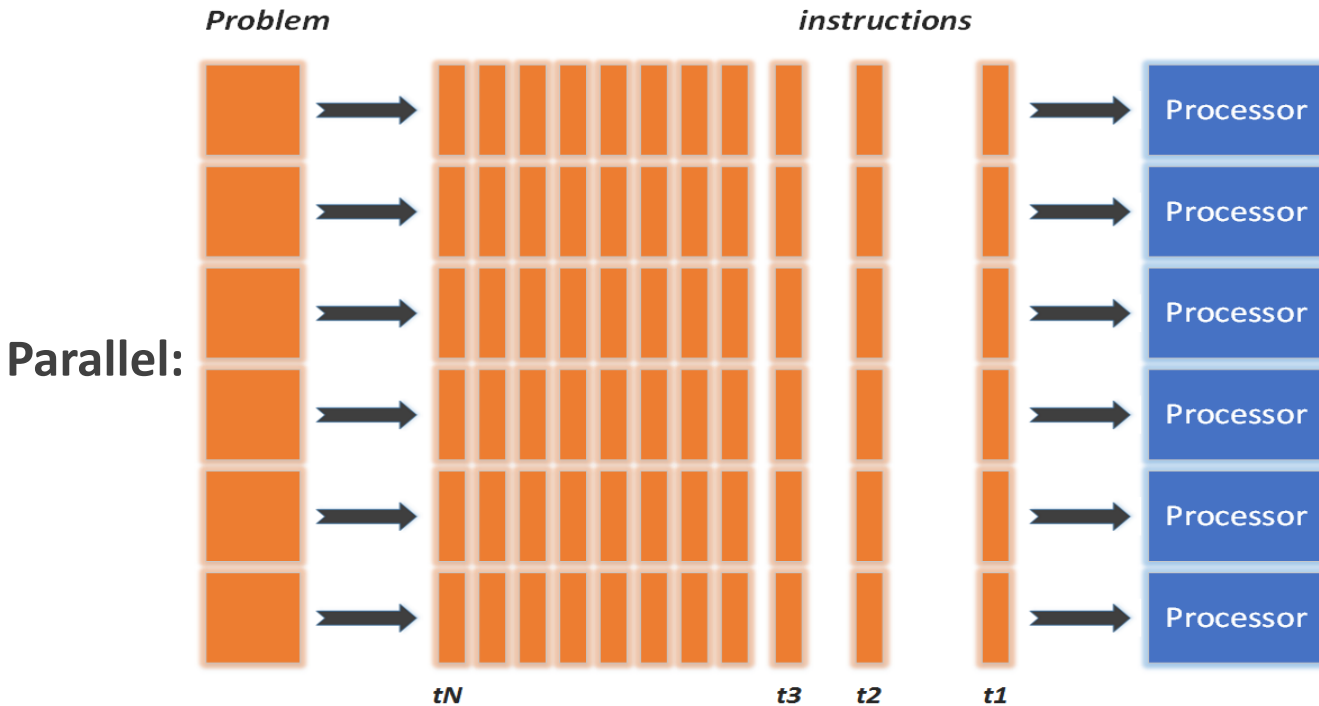

- ✓ Problem broken into parts can be solved **concurrently**
- ✓ Further broken into a series of instructions
- ✓ Instructions executed **simultaneously** on multiply processors
- ✓ **Synchronization/communication** mechanism employed

What is zcluster?

- Cluster Structural Diagram
- General Information
- Computing Resources
- Disk Storage

GACRC Linux HPC Zcluster Structural Diagram

Zcluster Connection Speed :

10 Gbit Ethernet 
1 Gbit Ethernet 

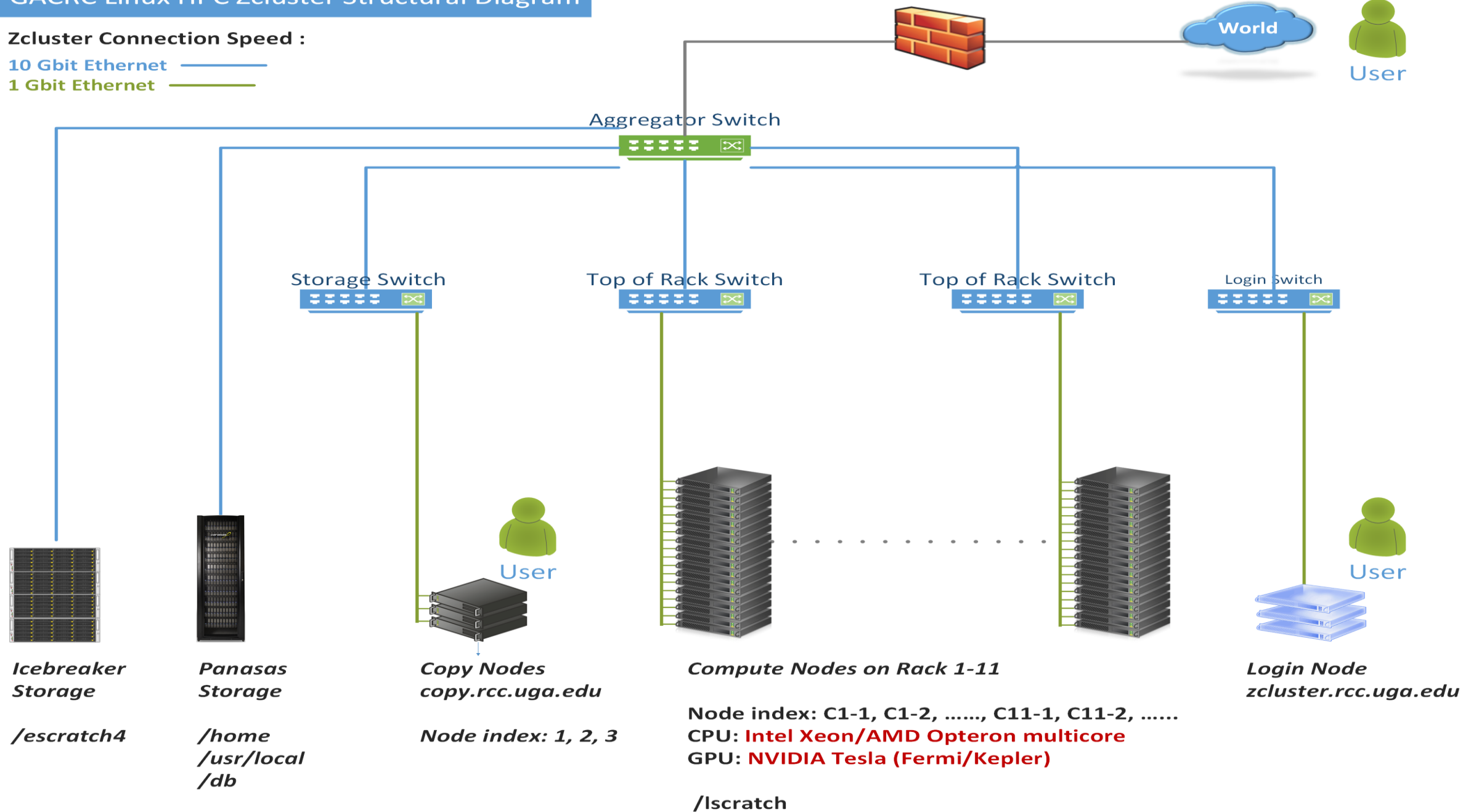

What is zcluster – General Information

zcluster is a Linux high performance computing (HPC) cluster:

- Operating System: **64-bit Red Hat Enterprise Linux 5 (RHEL 5)**
- Login Node: zcluster.rcc.uga.edu
Copy Node: copy.rcc.uga.edu
- Internodal Communication: **1Gbit** network
 - compute nodes ↔ compute nodes
 - compute nodes ↔ storage systems

What is zcluster – General Information

- Batch-queueing System:
 - Jobs can be started (submitted), monitored, and controlled
 - Determine which compute node is the best place to run a job
 - Determine appropriate execution priority for a job to run
- On zcluster: **Sun Grid Engine (SGE)**

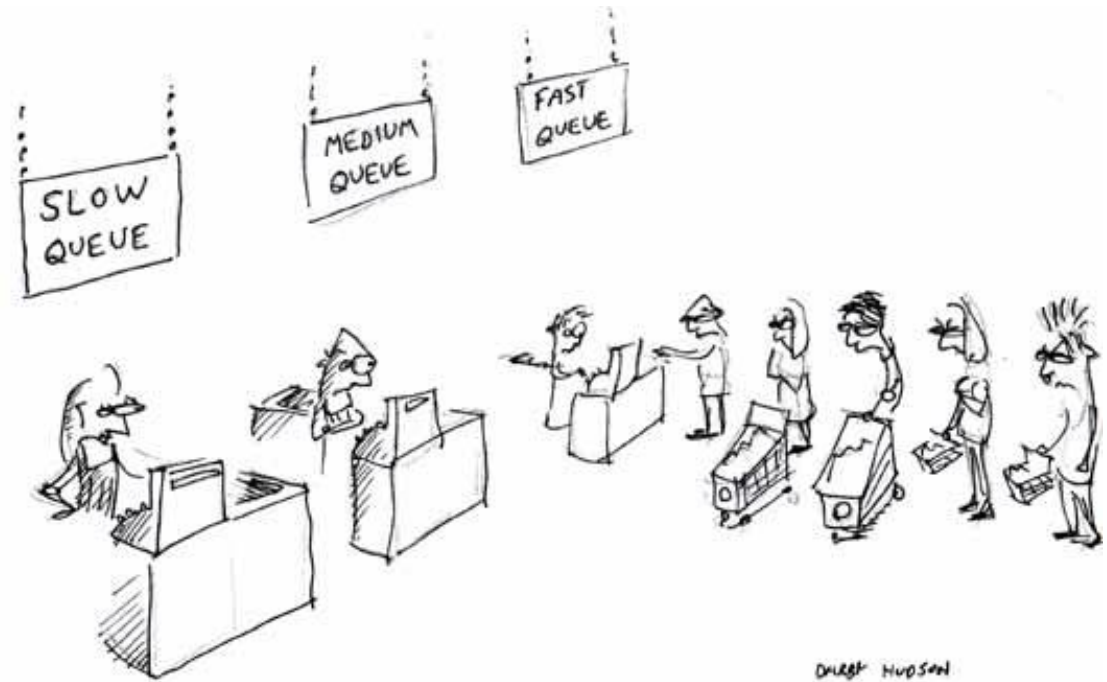

What is zcluster – Computing Resources



Queue Type	Queue Name	Nodes	Processor	Cores/Node	RAM(GB)/Node	Cores	NVIDIA GPU
Regular	rcc-30d	45	Intel Xeon	12	48	540	N/A
		150		8	16	1200	
High Memory	rcc-m128-30d	4	Intel Xeon	8	192	32	N/A
		10		12	256	120	
	rcc-m512-30d	2		32	512	64	
Multi Core	rcc-mc-30d	6	AMD Opteron	32	64	192	N/A
Interactive	interq	2	AMD Opteron	48	132	96	N/A
GPU	rcc-sgpu-30d	2	Intel Xeon	8	48	16	4 Tesla S1070 cards
	rcc-mgpu-30d	2		12	48	24	9 Tesla (Fermi) M2070 cards
	rcc-kgpu-30d	4		12	96	24	32 Tesla (Kepler) K20Xm cards

Total peak performance: 23 Tflops

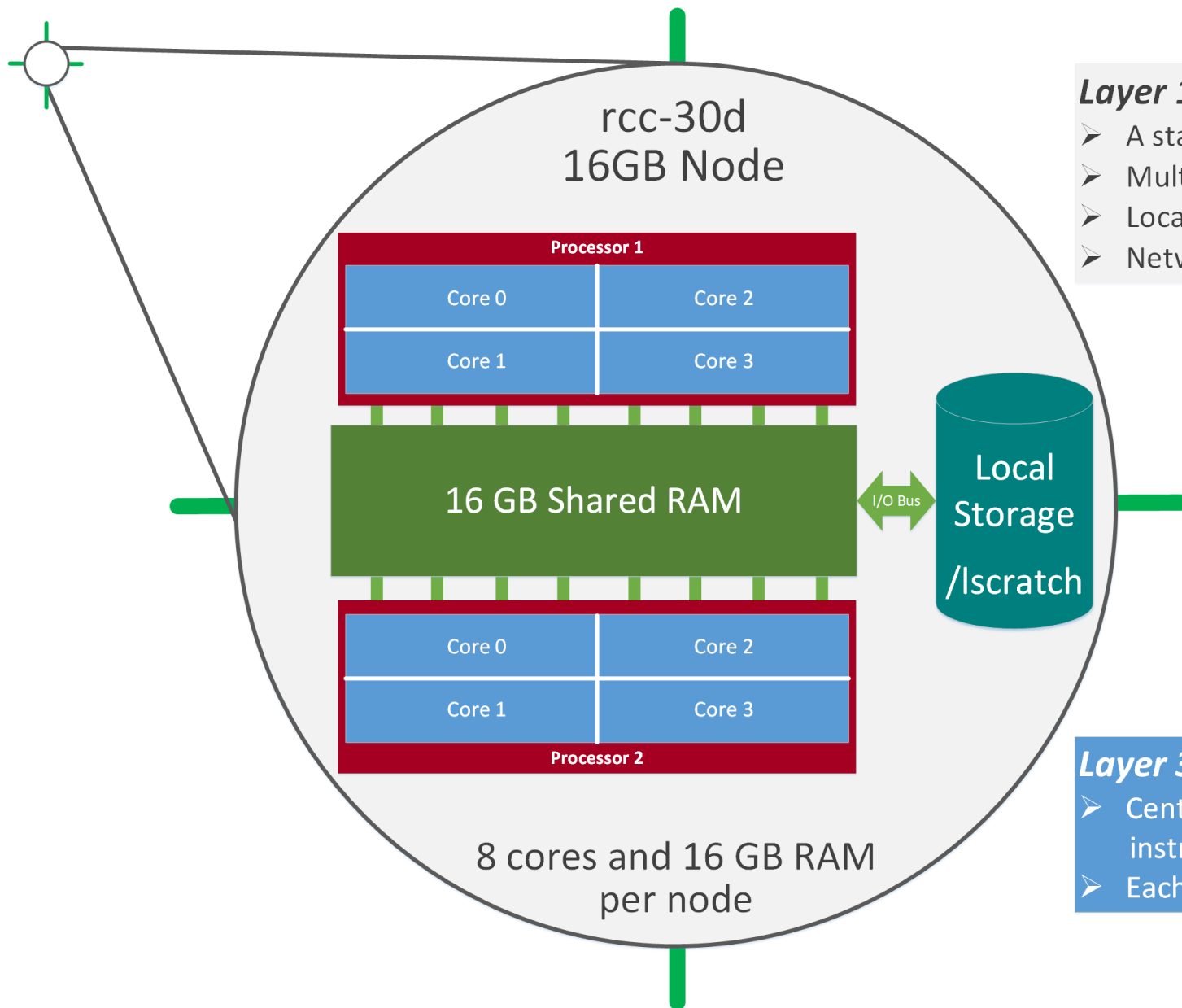

Layer 1: Node

- A standalone “computer in a box”
- Multiple processors, e.g. 2, sharing memory
- Local disk storage, network interface, etc.
- Networked into a cluster

Layer 2: Processor

- A single computing component
- Multicore processor, e.g. 4 cores

Layer 3: Core

- Central processing unit (CPU) reading and executing instructions independently
- Each core is assigned to a software thread

What is zcluster – Disk Storage

- **Home directory** → /home/student/stat8060/username (e.g., s_01, s_02, ...)
 - Mounted and visible on **all nodes**, with a quota of **~100GB**
 - Any directory on /home has **snapshot** backups
 - Taken once a day, and maintained **4 daily** ones and **1 weekly** one
 - Name: **.snapshot**, e.g., /home/abclab/jsmith/.snapshot
 - **Completely invisible**, however, user can “cd” into it and then “ls”:

```
zhuofei@zcluster:~$ ls -a
.          .bash_profile  .emacs.d      .fontconfig    .maple_history  MPIs      scripts  test.sh
..         .bashrc        .ENV_file     .gnuplot_history .Mathematica    openMPs   serials  .viminfo
.bash_history  downloads      exe           .history        .mc             .profile  sht      .Xauthority
.bash_logout  .emacs        .flexlmrc    .lessht        .mozilla        Pthreads  .ssh     ← .snapshot is NOT
zhuofei@zcluster:~$ cd .snapshot ← can “cd” into .snapshot      shown here!
zhuofei@zcluster:~/ .snapshot$ ls ← then “ls” to list its contents
2015.06.21.00.00.01.weekly  2015.06.27.01.00.01.daily  2015.06.28.01.00.01.daily  2015.06.30.01.00.01.daily
2015.06.26.01.00.01.daily  2015.06.28.00.00.01.weekly  2015.06.29.01.00.01.daily
```

What is zcluster – Disk Storage

- **Local scratch** → `/lscratch/username` (e.g., `s_01`, `s_02`, ...)
 - On **local disk** of each **compute** node → **node-local storage**
 - rcc-30d 8-core nodes: **~18GB**, rcc-30d 12-core nodes: **~370GB**
 - **No snapshot backup**
 - Usage Suggestion: *If your job writes results to `/lscratch`, job submission script should move the data to your home or `escratch` before exit*
- **Ephemeral Scratch** → `/escratch4/username_Aug_26` (e.g., `s_01_Aug_26`)
 - Create with `make_escratch` command
 - Visible to **all nodes** with a quota of **4TB**
 - **No snapshot backup**
 - To be deleted after **37 days**

How to work with zcluster?

Before we start:

- To get zcluster to be your best HPC buddy, go to
GACRC Wiki (<http://wiki.gacrc.uga.edu>)
GACRC Web (<http://gacrc.uga.edu>)
- To get the most effective and qualified support from us, go to
GACRC Support (https://wiki.gacrc.uga.edu/wiki/Getting_Help)
- To work happily and productively, follow the cluster's
Community Code of Conduct (**CCOC**)

How to work with it?

- Cluster's CCOC:

On cluster, you are not alone..... Each user is sharing finite resources, e.g., CPU cycles, RAM, disk storage, network bandwidth, with other researchers.

What you do may affect other researchers on the cluster.

6 rules of thumb to remember:

- NO jobs running on login node
- NO multi-threaded job running with only 1 core requested
- NO large memory job running on regular nodes
- NO long job running on interactive node
- NO small memory job running on large memory nodes
- Use the copy node for file transfer and compression



How to work with zcluster?

- Start with zcluster
- Connect & Login
- Transfer Files
- Softwares Installed
- Run Interactive Jobs
- Run Batch Jobs
 - How to run *serial* jobs
 - How to run *threaded* jobs
 - How to run *MPI* jobs
 - How to check job status, cancel a job, etc.

How to work with zcluster – Start with zcluster

- You need a **User Account**, e.g., : `s_01@zcluster.rcc.uga.edu`
- Procedure: https://wiki.gacrc.uga.edu/wiki/User_Accounts
- A UGA faculty member (**PI**) may register a computing lab:
<http://help.gacrc.uga.edu/labAcct.php>
- The PI of a computing lab may request user accounts for members of his/her computing lab: <http://help.gacrc.uga.edu/userAcct.php>
- User receives an email notification once the account is ready
- User can use `passwd` command to change initial temporary password

How to work with zcluster – Connect & Login

- Open a connection: Open a terminal and `ssh` to your account

```
ssh s_40@zcluster.rcc.uga.edu
```

or

```
ssh -X s_40@zcluster.rcc.uga.edu
```

⁽¹⁾ `-X` is for X windows application running on the cluster to be forwarded to your local machine

⁽²⁾ If using Windows, use `SSH client` to open connection, get from UGA download software page)

- Logging in: You will be prompted for your `zcluster password`

```
s_40@zcluster.rcc.uga.edu's password: █
```

⁽³⁾ On Linux/Mac, when you type in the password, the prompt blinks and does not move)

- Logging out: `exit` to leave the system

```
s_40@zcluster:~$ exit
```

How to work with zcluster – Transfer Files

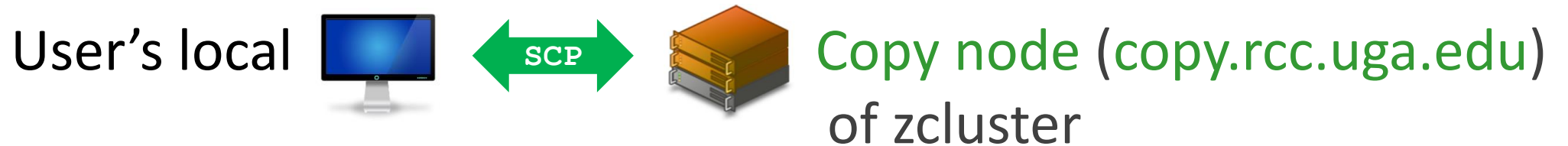

- On Linux, Mac or cygwin on Windows : `scp [Source] [Target]`

E.g. 1: On local machine, do Local → zcluster

```
scp file1 s_40@copy.rcc.uga.edu:~/subdir
```

```
scp *.dat s_40@copy.rcc.uga.edu:~/subdir
```

E.g. 2: On local machine, do zcluster → Local

```
scp s_40@copy.rcc.uga.edu:~/subdir/file ./
```

```
scp s_40@copy.rcc.uga.edu:~/subdir/*.dat ./
```

- On Window: **FileZilla**, **WinSCP**, etc.

How to work with zcluster – Softwares Installed

- Perl, Python, Java, awk, sed, C/C++ and Fortran compilers
- Matlab, Maple, R, **Julia**
- Many Bioinformatics applications: NCBI Blast+, Velvet, Trinity, TopHat, MrBayes, SoapDeNovo, Samtools, RaxML, etc.
- RCCBatchBlast (RCCBatchBlastPlus) to distribute NCBI Blast (NCBI Blast+) searches to multiple nodes.
- Many Bioinformatics Databases: NCBI Blast, Pfam, uniprot, etc.
- For a complete list of applications installed:
<https://wiki.gacrc.uga.edu/wiki/Software>

How to work with zcluster – Run Interactive Jobs

- To run an interactive job, you need to open a session on an **interactive node** using **qlogin** command:

```

zhuofei@zcluster:~$ qlogin
Your job 1391816 ("QLOGIN") has been submitted
waiting for interactive job to be scheduled ...
Your interactive job 1391816 has been successfully scheduled.
...
compute-14-7.local$ ← Now I am on compute-14-7, which is an interactive node
  
```

- Current maximum runtime is **12** hours
- When you are done, remember to **exit** the session! 
- Detailed information, like interactive parallel job? Go to: [https://wiki.gacrc.uga.edu/wiki/Running Jobs on zcluster](https://wiki.gacrc.uga.edu/wiki/Running_Jobs_on_zcluster)

How to work with zcluster – Run Batch Jobs

- Components you need to run a batch job:
 - **Software** already installed on zcluster (**Julia**)
 - **Job submission script** to run the software,
 - ✓ Specifying working directory
 - ✓ Exporting environment variables, e.g.,
 - OMP_NUM_THREADS (OpenMP threads number)
 - LD_LIBRARY_PATH (searching paths for shared libraries)
- Common commands you need:
 - **qsub** with specifying **queue name**, **threads** or **MPI rank number**
 - **qstat**, **qdel**
 - **qacct**, **qsj**, etc.

How to work with zcluster – Run Batch *Serial* Jobs

- **Step 1:** Create a job submission script *subserial.sh* running julia:

```
#!/bin/bash           → Linux shell (bash)

cd `pwd`             → Specify and enter (cd) the working directory (pwd command gives the path of your current directory)

/usr/local/julia/0.3.3/julia test.jl → Run julia script test.jl
```

- **Step 2:** Submit it to the queue:

```
$ qsub -q rcc-30d subserial.sh OR $ qsub -q rcc-30d -l mem_total=20g subserial.sh
```

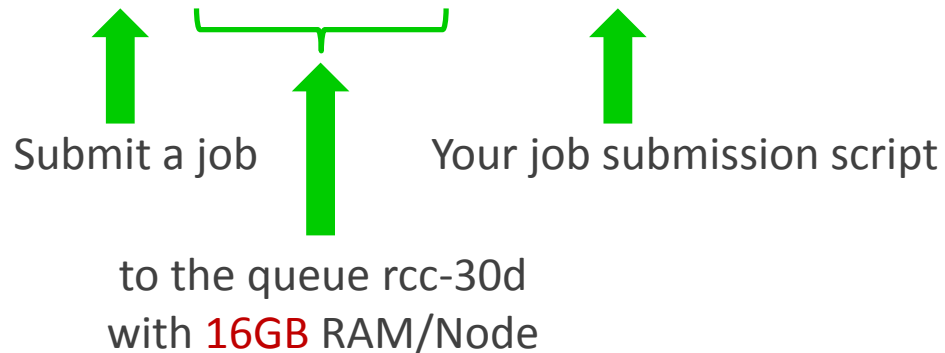

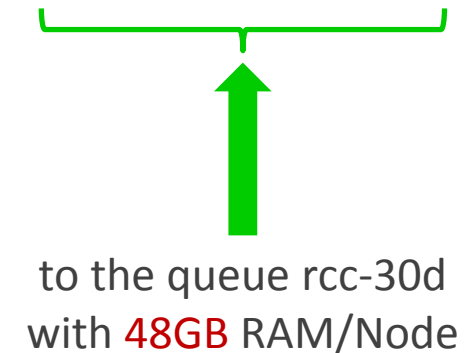

How to work with zcluster – Run Batch *Threaded* Jobs

- **Step 1:** Create a job submission script *subthread.sh* running julia:

```
#!/bin/bash

cd `pwd`

/usr/local/julia/0.3.3/julia -p 4 test.jl
```

→ Run julia with 4 threads (-p 4)

Number of Threads =
Number of Cores Requested

- **Step 2:** Submit it to the queue:

```
$ qsub -q rcc-30d -l mem_total=20g -pe thread 4 subthread.sh
```

to the queue rcc-30d
with 48GB RAM/Node

4 cores requested

Note:
Please use the *rcc-mc-30d* queue,
If using threads *more than 8!*

How to work with zcluster – Run Batch *MPI* Jobs

- **Step 1:** Create a job submission script *submpi.sh* running julia:

```
#!/bin/bash

cd `pwd`

/usr/local/julia/0.3.3/julia -p  $\${NSLOTS}$  --machinefile  $\${TMPDIR}/machines test.jl$  → Run julia with 12 MPI processes (-np  $\${NSLOTS}$ )
```

- **Step 2:** Submit it to the queue:

```
$ qsub -q rcc-30d -pe mpi 12 submpi.sh
```

12 cores requested,
 $\${NSLOTS}$ will be assigned to 12 automatically, before
the job submission script is interpreted

How to work with zcluster – Check and Cancel Jobs

- To check the status of all queued and running jobs: **qstat**

```
qstat           → shows your job in the pool
qstat -u "*"    → shows all the jobs in the pool
qstat -j 12345  → shows detailed information, e.g., maxvmem, about the job with JOBID 12345
qstat -g t      → list all nodes used by your jobs
```

- To cancel a queued or running job: **qdel**

```
qdel -u zhuofei → deleted all your jobs
qdel 12345      → deletes your job with JOBID 12345
```

- To list detailed information about a job: **qsj**, **qacct**

```
qsj 12345      → shows information, e.g., maxvmem, about the RUNNING job with JOBID 12345
qacct -j 12345 → shows information, e.g., maxvmem, about the ENDED job with JOBID 12345
```

Thank You!
Good Luck STAT8060!

A solid blue horizontal bar spans the bottom of the slide.

From Yecheng:

- Software support issue:

What kind of software support we are responsible for the users? or definition of our software support

From Shan-Ho:

- rcc-30d : For MPI, max 75 cores total to be requested
- rcc-mc-30d : max 32 threads to be allowed
- rcc-m128-30d: max 5 cores to be requested
- rcc-m512-30d: max 8 cores to be requested